



Savings and Application Guide for Power Factor Correction and Harmonic Solutions

Aerovox®

Savings and Application Guide for Power Factor Correction and Harmonic Solutions

CONTENTS

Capacitor Function	3
Equipment Causing Poor Power Factor	3
How Power Factor Correction Capacitors Save Money.....	3
Benefits of Power Factor Improvement.....	4
Facts and Formulas.....	7
Degree of Power Factor Improvement	8
Size of Capacitor Bank	8
Determining Your Capacitor Requirements	9
Sizing Capacitors for Electrical Systems	10
Power Bill Savings	11
Factors That Affect an Electrical Bill	12
Location of Power Capacitors.....	13
Suggested Maximum Capacitor Ratings for U-Frame and T-Frame Motors When Switched with Capacitors	14
Switching Capacitors.....	15
Guide for Cable and Switch Selection.....	16
Understanding Harmonics	17
Applying Power Factor Correction in a Harmonic Environment.....	18

Function of Capacitors

Electric power has two components:

Active power, which produces work.

Reactive power, which is needed to generate magnetic fields required for operation of inductive electrical equipment, but performs no useful work.

Active power is measured in KW (1000 Watts)

Reactive power is measured in KVAR (1000 Volt-Amperes Reactive)

Total power is measured in KVA (1000 Volt-Amperes)

The ratio of **working power** to total power is called **power factor**. The function of power factor correction capacitors is to increase the power factor by supplying reactive power when installed at or near inductive electrical equipment.

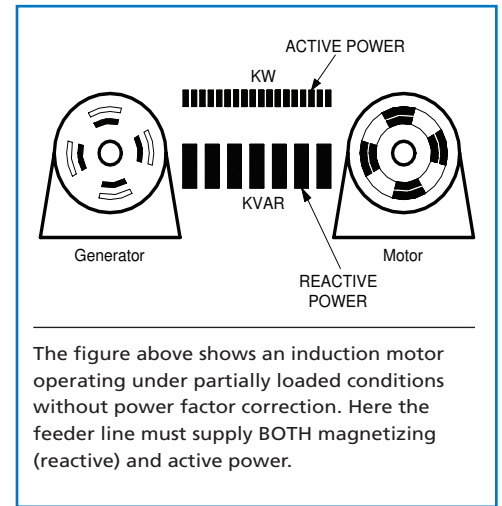

Equipment Causing Poor Power Factor

A great deal of equipment causes poor power factor. One of the worst offenders is lightly loaded induction equipment. Examples of this type of equipment, and their approximate power factors follow:

80% power factor or better:

Air conditioners (correctly sized), pumps, centerless grinders, cold headers, upsetters, fans or blowers.

60% to 80% power factor:

Induction furnaces, standard stamping machines, and weaving machines.

60% power factor and below:

Single-stroke presses, automated machine tools, finish grinders, welders.

Savings can be achieved by utilizing Aerovox industrial capacitors when the above equipment is used within a facility.

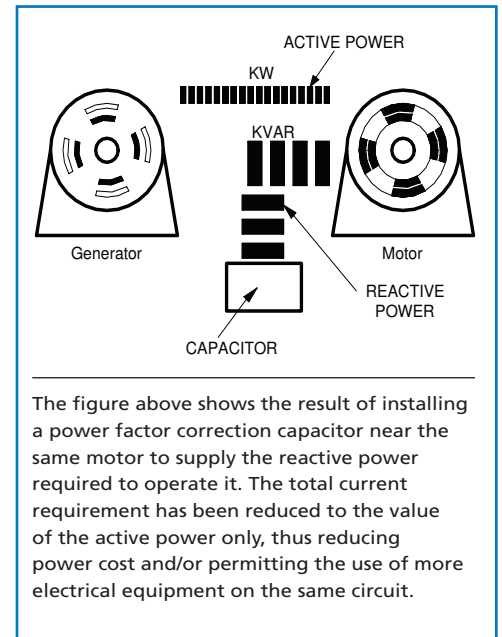

How Power Factor Correction Capacitors Save Money

Power factor correction capacitors lower electrical costs two ways:

In many areas, the electrical rate includes a penalty charge for low power factor. Installation of power capacitors on the electrical distribution system within a facility makes it unnecessary for the utility to supply the reactive power required by inductive electrical equipment. The savings the utility realizes in reduced generation, transmission, and distribution costs are passed on to the customer in the form of lower electrical bills.

The second source of savings derived through the use of power factor correction capacitors is in the form of increased KVA capacity in the electrical distribution system. Installation of capacitors to furnish the non-productive current requirements of the facility makes it possible to increase the connected load by as much as 20% without a corresponding increase in the size of the transformers, conductors, and protective devices making up the distribution system which services the load.

Benefits of Power Factor Improvement

Power factor (PF) is the ratio of useful current to total current. It is also the ratio of useful power expressed in kilowatts (KW) to total power expressed in kilowatt-amperes (KVA). Power factor is usually expressed as a decimal or as a percentage.

Example: KW = 60, KVA = 100

$$PF = \frac{\text{Useful Power}}{\text{Total Power}} = \frac{60 \text{ KW}}{100 \text{ KVA}} = .60 = 60\%$$

The significant effect of improving the power factor of a circuit is to reduce the current flowing through that circuit which in turn results in the following benefits:

Benefit No. 1

Less Total Plant KVA for the Same KW Working Power

Dollar savings are very significant in areas where utility billing is affected by KVA usage.

$$KVA = \sqrt{3} \times KV \times I$$

Example: 600 KW working power vs. KVA required

Power Factor	60%	70%	80%	90%	100%
Active Power	600 KW	600 KW	600 KW	600 KW	600 KW
Reactive Power	800 KVAR	612 KVAR	450 KVAR	291 KVAR	0 KVAR
Total Power	1000 KVA	857 KVA	750 KVA	667 KVA	600 KVA

Power factor correction capacitors allow for more efficient operation of plant transformers and “free up” KVA for additional load. Cost avoidance can be significant.

Benefit No. 2

More KW Working Power for the Same KVA Demand

Released system capacity allows for additional motors, lighting, etc. to be added without overloading existing distribution equipment.

Example: 600 KVA demand vs. available KW

$$KW = KVA \times PF$$

Power Factor	60%	70%	80%	90%	100%
Active Power	360 KW	420 KW	480 KW	540 KW	600 KW
Reactive Power	480 KVAR	428 KVAR	360 KVAR	262 KVAR	0 KVAR
Total Power	600 KVA	600 KVA	600 KVA	600 KVA	600 KVA

Benefit No. 3

Improved Voltage Regulation Due to Reduced Line Voltage Drop

This benefit results in more efficient performance of motors and other electrical equipment.

Example: The graphs below track the full load speed and starting torque of a motor at various levels of rated voltage.

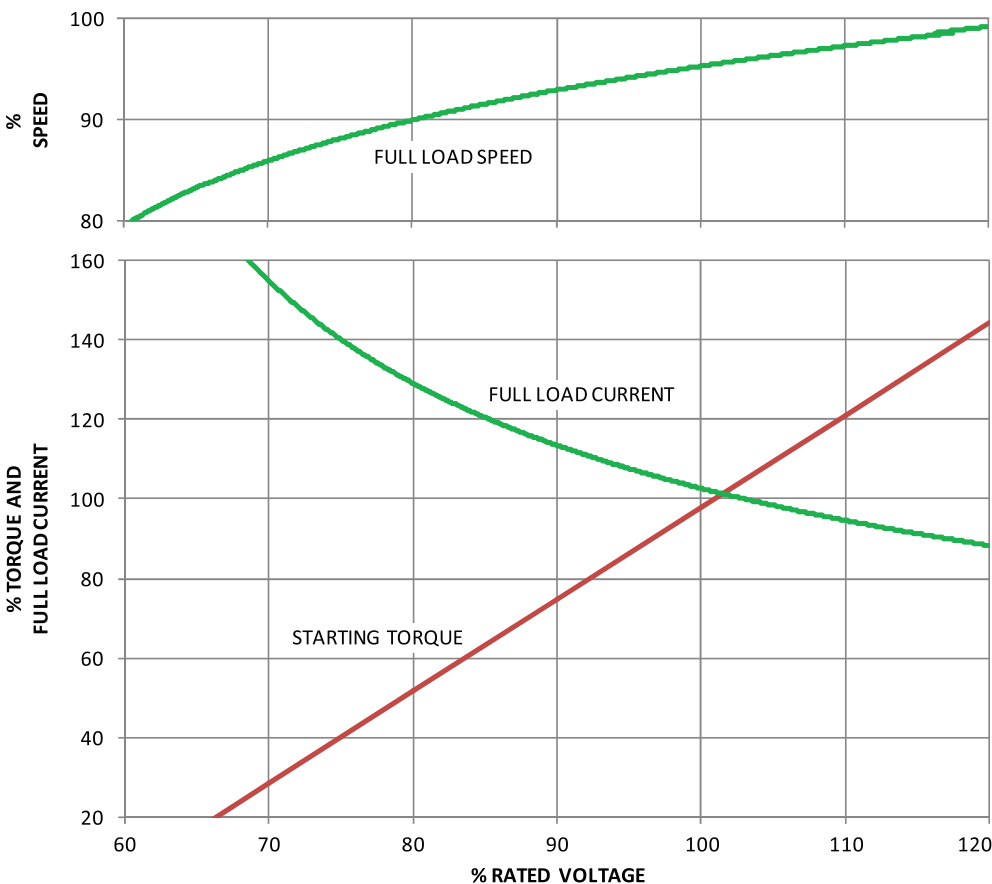

$$\% \text{ voltage rise}^* = \frac{KVAR \times \%Z_L}{KVA \text{ of transformer}}$$

* with capacitor at the transformer
 Z_L = transformer impedance % from nameplate

Benefit No. 4

Reduction in Size of Transformers, Cables and Switchgear in New Installations Reduces Overall Investment

Example: The figures below represent the increasing size of conductors required to carry the same 100 KW at various power factors.

$$I = \frac{KVA \times 10^3}{\sqrt{3}V}$$

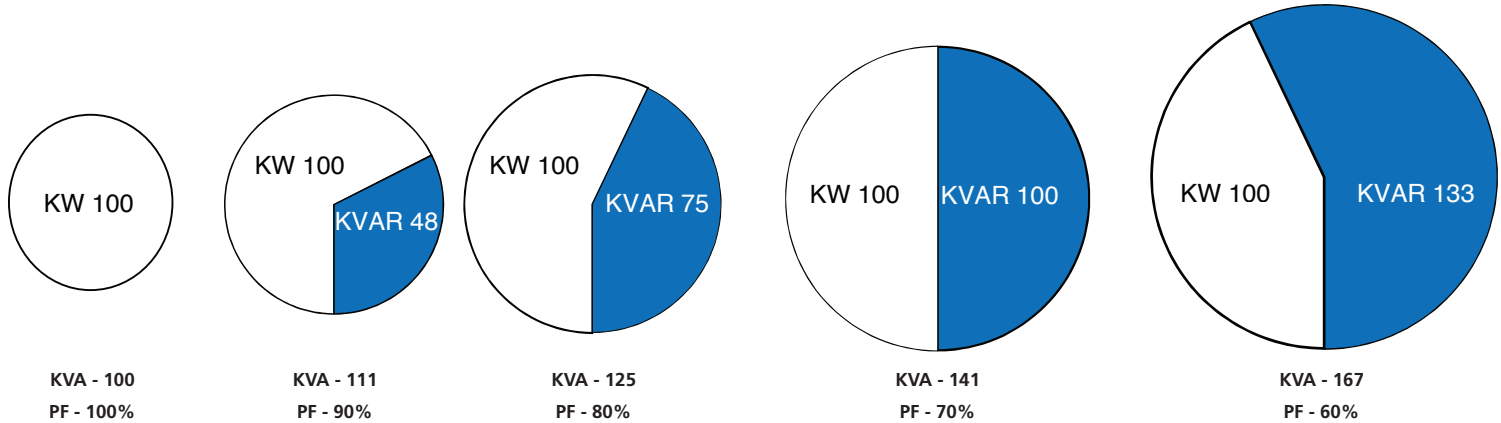

Benefit No. 5

Reduced Power Losses in Distribution Systems

Since the losses are proportionate to the square of the current, the formula at right applies.

Example: Power Factor Correction Capacitors improve power factor from 65 percent to 90 percent in the following example.

$$\text{Reduction of power losses} = 100 - 100 \left(\frac{.65}{.90} \right)^2 = 48\%$$

$$\begin{aligned} &\% \text{ reduction of power} \\ &\text{losses} = \\ &100 - 100 \left(\frac{\text{original PF}}{\text{new PF}} \right)^2 \end{aligned}$$

Facts and Formulas

$$1. \quad PF = \cos \theta = \frac{KW}{KVA} \quad (\text{motor input})$$

$$2. \quad KW (\text{motor input}) = \frac{hp \times .746}{\% \text{ Eff}}$$

$$3. \quad KVA = \frac{\sqrt{3} \times V \times I}{10^3} \quad (\text{three phase})$$

$$4. \quad KVA = \frac{V \times I}{1000} \quad (\text{single phase})$$

$$5. \quad KVA = \frac{KW}{PF} = \sqrt{(KW)^2 + (KVAR)^2}$$

$$6. \quad I = \frac{KVA \times 10^3}{\sqrt{3}V} \quad (\text{three phase})$$

$$7. \quad I = \frac{KVA \times 10^3}{V} \quad (\text{single phase})$$

$$8. \quad KVAR = \frac{2\pi fC (KV)^2}{10^3}$$

$$9. \quad C = \frac{KVAR \times 10^3}{(2\pi f)(KV)^2}$$

$$10. \quad X_C = \frac{10^6}{(2\pi f)C}$$

Legend:

K = 1000

W = watts

V = volts

A = amperes

hp = horsepower

PF = power factor

I = line current (amperes)

I_C = capacitor current (amperes)

C = capacitance (microfarads)

f = frequency

X_C = capacitive reactance

Derating for V & f

$$KVAR_E = KVAR_R \left(\frac{V_A}{V_R} \right)^2 \left(\frac{f_A}{f_R} \right)$$

$KVAR_E$ = Effective KVAR

$KVAR_R$ = Rated KVAR

V_A = Applied Voltage

V_R = Rated Voltage

f_A = Applied frequency

f_R = Rated frequency

Examples:

- Reduced KVAR when operating 60 Hz unit @ 50 Hz

$$\text{Actual KVAR} = \text{Rated KVAR} \left(\frac{50}{60} \right) = 83\% \text{ rated KVAR}$$

- Reduced KVAR when operating @ below rated voltage

$$\text{Actual KVAR} = \text{rated KVAR} \left(\frac{\text{operating voltage}}{\text{rated voltage}} \right)^2$$

i.e.: 240 V @ 208 V = .75 rated KVAR

Degree of Power Factor Improvement

As noted on page 3, power capacitors lower costs two ways. To determine how much improvement should be made to the existing power factor, one must analyze the potential benefits to be gained in each situation.

Goal No. 1

Utility Bill Savings

If utility bill savings are a factor, it is recommended that the past 12 months' billings be reviewed and compared to potential billings at improved power factor levels. Since there are a variety of rate structures in existence, each case must be investigated separately. In general, where penalty clauses exist, the power factor should be raised to at least 95 percent.

Goal No. 2

Relief of Overloaded Distribution System

Where relief of an overloaded distribution system is the major consideration, the degree of correction will depend upon the amount of relief required. In some instances, correction to unity may be economical.

Size of Capacitor Bank

Where the size of the capacitor bank needed to improve power factor to the desired level (usually 95%) is not readily available from Motor Tables or by graphic determination, it can be calculated as shown on page 9 or by these formulas.

To Find	When You Know	Three-Phase
Watts input to anything	Output, efficiency	$\frac{\text{Watts output}}{\% \text{ efficiency}}$
Watts input to a motor	Horsepower, efficiency	$\frac{\text{hp} \times .746 \times \text{LF}}{\% \text{ efficiency}}$
Horsepower (Output)	Current, voltage, efficiency, power factor	$\frac{1.73 \times E \times I \times \% \text{eff.} \times \text{PF}}{.746}$
Kilovolt-amperes	Current, voltage	$\frac{1.73 \times E \times I}{1000}$
Kilowatts	Current, voltage, power factor	$\frac{1.73 \times E \times I \times \text{PF}}{1000}$
Amperes	Horsepower, voltage, efficiency, power factor	$\frac{\text{hp} \times .746 \times \text{LF}}{1.73 \times E \times \% \text{eff.} \times \text{PF}}$
Amperes	Kilowatts, voltage, power factor	$\frac{\text{KW} \times 1000}{1.73 \times E \times \text{PF}}$
Amperes	Kilovolt-amperes, voltage	$\frac{\text{KVA} \times 1000}{1.73 \times E}$
Power factor	Watts, voltage, current	$\frac{\text{Watts}}{1.73 \times E \times I}$
Power factor	Kilowatts, voltage, current	$\frac{\text{kw} \times 1000}{1.73 \times E \times I}$

PF = power factor E = volts LF = load factor I = current in amperes

Determining Your Capacitor Requirements

The total KVAR rating of capacitors required to improve a facility's power factor to any desired value may be calculated very easily by using several basic formulas and by applying the appropriate multiplier selected from **Table 1** on page 10.

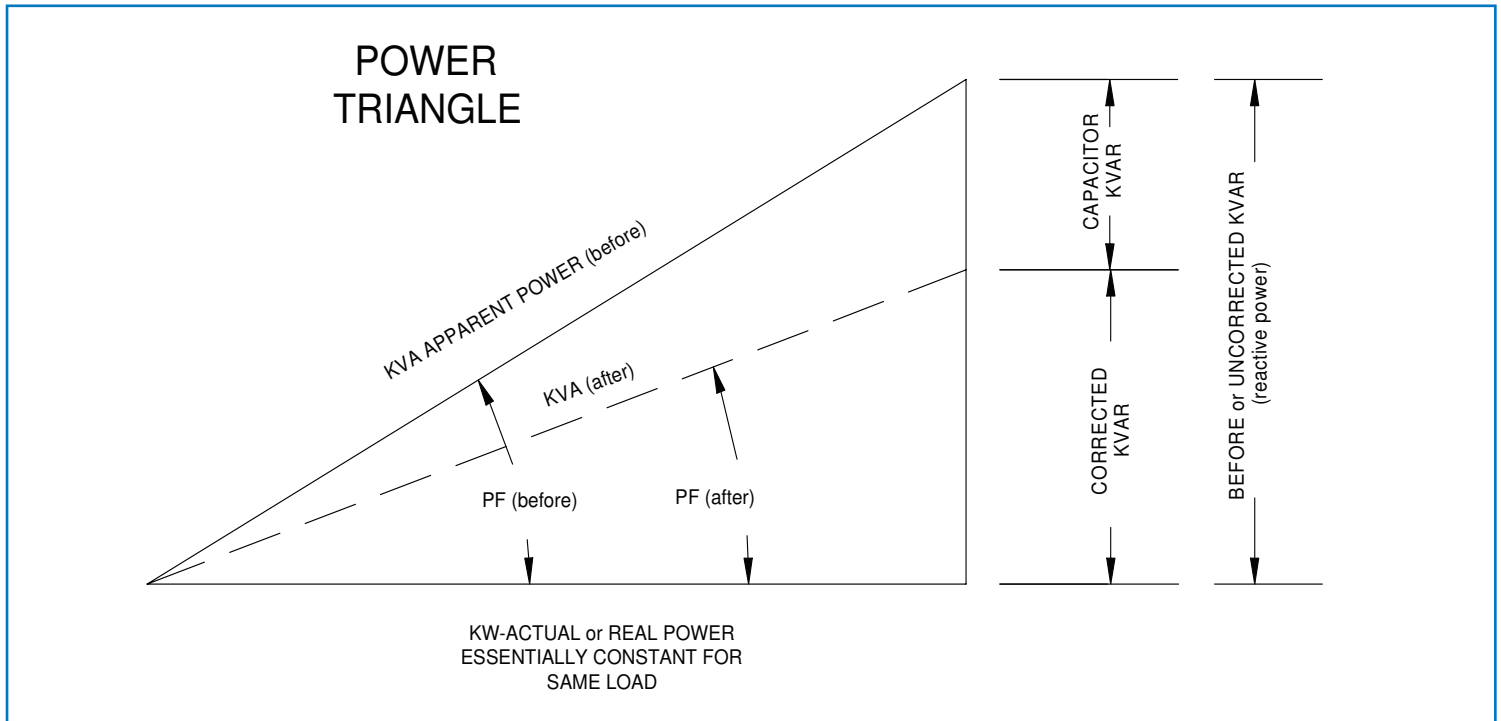

Examples:

- A plant with a metered demand of 600 KW is operating at a 75% power factor. What capacitor KVAR is required to correct the present power factor to 95%?
 - From **Table 1**, multiplier to improve PF from 75% to 95% is .553.
 - Capacitor KVAR = KW x Table 1 Multiplier
Capacitor KVAR = 600 x .553 = 331.8
- A plant load of 425 KW has a total power requirement of 670 KVA. What size capacitor is required to improve the present power factor to 90%?
 - Present PF = $\frac{425}{670} = .634 = 63.4\%$
 - From Table 1, multiplier to improve PF from 63% to 90% is .748.
 - Capacitor KVAR = KW x **Table 1** Multiplier = 425 x .748 = 317.9
- A plant operating from a 480 volt system has a metered demand of 258 KW. The line current read by a clip-on ammeter is 420 amperes. What capacitors KVAR is required to correct the present power factor to 90%?
 - $KVAR = 1.73 \times KV \times I = 1.73 \times .480 \times 420 = 349 \text{ KVA}$
 - Present PF = $\frac{258}{349} = .739 = 73.9\%$ say 74%
 - From **Table 1**, Multiplier to improve PF from 74% to 90% is .425.
 - Capacitor KVAR = KW x Table 1 Multiplier = 258 x .425 = 109.6

Table 1
Sizing Capacitors for Electrical Systems

Table 1 gives multipliers for KW to get the capacitor KVAR needed to increase from original to desired corrected power factor. Use the multipliers to size auto-switched or fixed capacitors for large loads.

		Desired Corrected Power Factor (%)																			
		80	81	82	83	84	85	86	87	88	89	90	91	92	93	94	95	96	97	98	99
50	0.982	1.008	1.034	1.060	1.086	1.112	1.139	1.165	1.192	1.220	1.248	1.276	1.306	1.337	1.369	1.403	1.440	1.481	1.529	1.590	1.732
51	0.937	0.963	0.989	1.015	1.041	1.067	1.093	1.120	1.147	1.174	1.202	1.231	1.261	1.291	1.324	1.358	1.395	1.436	1.484	1.544	1.687
52	0.893	0.919	0.945	0.971	0.997	1.023	1.049	1.076	1.103	1.130	1.158	1.187	1.217	1.247	1.280	1.314	1.351	1.392	1.440	1.500	1.643
53	0.850	0.876	0.902	0.928	0.954	0.980	1.007	1.033	1.060	1.088	1.116	1.144	1.174	1.205	1.237	1.271	1.308	1.349	1.397	1.458	1.600
54	0.809	0.835	0.861	0.887	0.913	0.939	0.965	0.992	1.019	1.046	1.074	1.103	1.133	1.163	1.196	1.230	1.267	1.308	1.356	1.416	1.559
55	0.768	0.794	0.820	0.846	0.873	0.899	0.925	0.952	0.979	1.006	1.034	1.063	1.092	1.123	1.156	1.190	1.227	1.268	1.315	1.376	1.518
56	0.729	0.755	0.781	0.807	0.834	0.860	0.886	0.913	0.940	0.967	0.995	1.024	1.053	1.084	1.116	1.151	1.188	1.229	1.276	1.337	1.479
57	0.691	0.717	0.743	0.769	0.796	0.822	0.848	0.875	0.902	0.929	0.957	0.986	1.015	1.046	1.079	1.113	1.150	1.191	1.238	1.299	1.441
58	0.655	0.681	0.707	0.733	0.759	0.785	0.811	0.838	0.865	0.892	0.920	0.949	0.979	1.009	1.042	1.076	1.113	1.154	1.201	1.262	1.405
59	0.618	0.644	0.670	0.696	0.723	0.749	0.775	0.802	0.829	0.856	0.884	0.913	0.942	0.973	1.006	1.040	1.077	1.118	1.165	1.226	1.368
60	0.583	0.609	0.635	0.661	0.687	0.714	0.740	0.767	0.794	0.821	0.849	0.878	0.907	0.938	0.970	1.005	1.042	1.083	1.130	1.191	1.333
61	0.549	0.575	0.601	0.627	0.653	0.679	0.706	0.732	0.759	0.787	0.815	0.843	0.873	0.904	0.936	0.970	1.007	1.048	1.096	1.157	1.299
62	0.515	0.541	0.567	0.593	0.620	0.646	0.672	0.699	0.726	0.753	0.781	0.810	0.839	0.870	0.903	0.937	0.974	1.015	1.062	1.123	1.265
63	0.483	0.509	0.535	0.561	0.587	0.613	0.639	0.666	0.693	0.720	0.748	0.777	0.807	0.837	0.870	0.904	0.941	0.982	1.030	1.090	1.233
64	0.451	0.477	0.503	0.529	0.555	0.581	0.607	0.634	0.661	0.688	0.716	0.745	0.775	0.805	0.838	0.872	0.909	0.950	0.998	1.058	1.201
65	0.419	0.445	0.471	0.497	0.523	0.549	0.576	0.602	0.629	0.657	0.685	0.714	0.743	0.774	0.806	0.840	0.877	0.919	0.966	1.027	1.169
66	0.388	0.414	0.440	0.466	0.492	0.519	0.545	0.572	0.599	0.626	0.654	0.683	0.712	0.743	0.775	0.810	0.847	0.888	0.935	0.996	1.138
67	0.358	0.384	0.410	0.436	0.462	0.488	0.515	0.541	0.568	0.596	0.624	0.652	0.682	0.713	0.745	0.779	0.816	0.857	0.905	0.966	1.108
68	0.328	0.354	0.380	0.406	0.432	0.459	0.485	0.512	0.539	0.566	0.594	0.623	0.652	0.683	0.715	0.750	0.787	0.828	0.875	0.936	1.078
69	0.299	0.325	0.351	0.377	0.403	0.429	0.456	0.482	0.509	0.537	0.565	0.593	0.623	0.654	0.686	0.720	0.757	0.798	0.846	0.907	1.049
70	0.270	0.296	0.322	0.348	0.374	0.400	0.427	0.453	0.480	0.508	0.536	0.565	0.594	0.625	0.657	0.692	0.729	0.770	0.817	0.878	1.020
71	0.242	0.268	0.294	0.320	0.346	0.372	0.398	0.425	0.452	0.480	0.508	0.536	0.566	0.597	0.629	0.663	0.700	0.741	0.789	0.849	0.992
72	0.214	0.240	0.266	0.292	0.318	0.344	0.370	0.397	0.424	0.452	0.480	0.508	0.538	0.569	0.601	0.635	0.672	0.713	0.761	0.821	0.964
73	0.186	0.212	0.238	0.264	0.290	0.316	0.343	0.370	0.396	0.424	0.452	0.481	0.510	0.541	0.573	0.608	0.645	0.686	0.733	0.794	0.936
74	0.159	0.185	0.211	0.237	0.263	0.289	0.316	0.342	0.369	0.397	0.425	0.453	0.483	0.514	0.546	0.580	0.617	0.658	0.706	0.766	0.909
75	0.132	0.158	0.184	0.210	0.236	0.262	0.289	0.315	0.342	0.370	0.398	0.426	0.456	0.487	0.519	0.553	0.590	0.631	0.679	0.739	0.882
76	0.105	0.131	0.157	0.183	0.209	0.235	0.262	0.288	0.315	0.343	0.371	0.400	0.429	0.460	0.492	0.526	0.563	0.605	0.652	0.713	0.855
77	0.079	0.105	0.131	0.157	0.183	0.209	0.235	0.262	0.289	0.316	0.344	0.373	0.403	0.433	0.466	0.500	0.537	0.578	0.626	0.686	0.829
78	0.052	0.078	0.104	0.130	0.156	0.183	0.209	0.236	0.263	0.290	0.318	0.347	0.376	0.407	0.439	0.474	0.511	0.552	0.599	0.660	0.802
79	0.026	0.052	0.078	0.104	0.130	0.156	0.183	0.209	0.236	0.264	0.292	0.320	0.350	0.381	0.413	0.447	0.484	0.525	0.573	0.634	0.776
80	0.000	0.026	0.052	0.078	0.104	0.130	0.157	0.183	0.210	0.238	0.266	0.294	0.324	0.355	0.387	0.421	0.458	0.499	0.547	0.608	0.750
81		0.000	0.026	0.052	0.078	0.104	0.131	0.157	0.184	0.212	0.240	0.268	0.298	0.329	0.361	0.395	0.432	0.473	0.521	0.581	0.724
82			0.000	0.026	0.052	0.078	0.105	0.131	0.158	0.186	0.214	0.242	0.272	0.303	0.335	0.369	0.406	0.447	0.495	0.556	0.698
83				0.000	0.026	0.052	0.079	0.105	0.132	0.160	0.188	0.216	0.246	0.277	0.309	0.343	0.380	0.421	0.469	0.530	0.672
84					0.000	0.026	0.053	0.079	0.106	0.134	0.162	0.190	0.220	0.251	0.283	0.317	0.354	0.395	0.443	0.503	0.646
85						0.000	0.026	0.053	0.080	0.107	0.135	0.164	0.194	0.225	0.257	0.291	0.328	0.369	0.417	0.477	0.620
86							0.000	0.027	0.054	0.081	0.109	0.138	0.167	0.198	0.230	0.265	0.302	0.343	0.390	0.451	0.593
87								0.000	0.027	0.054	0.082	0.111	0.141	0.172	0.204	0.238	0.275	0.316	0.364	0.424	0.567
88									0.000	0.027	0.055	0.084	0.114	0.145	0.177	0.211	0.248	0.289	0.337	0.397	0.540
89										0.000	0.028	0.057	0.086	0.117	0.149	0.184	0.221	0.262	0.309	0.370	0.512
90											0.000	0.029	0.058	0.089	0.121	0.156	0.193	0.234	0.281	0.342	0.484
91												0.000	0.030	0.060	0.093	0.127	0.164	0.205	0.253	0.313	0.456
92													0.000	0.031	0.063	0.097	0.134	0.175	0.223	0.284	0.426
93														0.000	0.032	0.067	0.104	0.145	0.192	0.253	0.395
94															0.000	0.034	0.071	0.112	0.160	0.220	0.363
95																0.000	0.037	0.078	0.126	0.186	0.329
96																	0.000	0.041	0.089	0.149	0.292
97																		0.000	0.048	0.108	0.251
98																			0.000	0.061	0.203
99																				0.000	0.142
100																					0.000

Example: Total KW input of load from wattmeter reading 100 KW at a power factor of 60%. The leading reactive KVAR necessary to raise the power factor to 90% is found by multiplying the 100 KW by the factor found in the table, which is .849. Then 100 KW x 0.849 = 84.9 KVAR. Use 85 KVAR.

Power Bill Savings

Poor power factor necessitates increased generation and transmission costs to provide the required amount of real power (KW). In order to equitably distribute these costs to the user, many utilities utilize a rate structure that penalizes poor power factor. These charges will be in the demand charge section of the utility bill, but this charge differs from utility to utility. The power bill savings can be computed by the utility company upon request.

Listed below is a savings estimate from a utility company in the northeast USA.

Demand Charge Section of Bill with Uncorrected Power Factor			
Power Factor 80%		KW 764.2	
Charges	Cost/KVA	KVA*	Total
Transmission	\$6.69	\$955.3	\$6,390.62
Distribution	\$0.88	\$955.3	\$840.62
Transition	\$3.00	\$955.3	\$2,865.75
Total Demand Charge			\$10,096.99
Demand Charge Section of Bill with Corrected Power Factor			
Power Factor 98%		KW 764.2	
Charges	Cost/KVA	KVA*	Total
Transmission	\$6.69	\$779.8	\$5,216.83
Distribution	\$0.88	\$779.8	2,339.39
Transistion	\$3.00	\$779.8	\$2,339.39
Total Demand Charge			\$8,242.44
Total Savings for Month			\$1,854.55

KW = The peak power usage for the month

$$*KVA = \frac{KW}{\text{Power Factor}}$$

Payback Analysis

600 KVAR Automatic Correction System	
Cost of System	\$16,400.00
Average Monthly Savings	\$1,854.55
Months for Full Payback	9

600 KVAR system is based on the possibility that some months may have more KVAR correction needed.

Factors That Affect an Electric Bill

1. Energy Charge

Number of kilowatt-hours used during the billing period. Number of kilovolt-amperes (KVA) used during the billing period.

2. Demand Charge

This charge compensates the utility for the capital investment required to serve the facility's peak load. Demand charges may be a large portion of the total electric bill, sometimes as high as 75%. Demand charges can be reduced by reducing energy peaks, reducing KVA, and improving power factor.

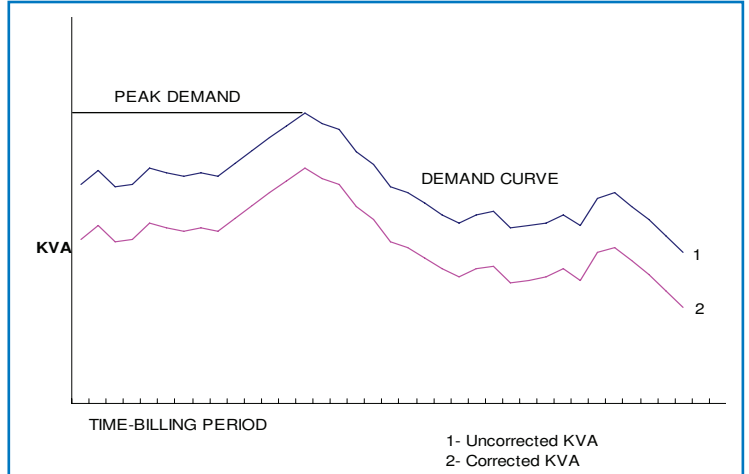

3. Power Factor Penalty Charge

A penalty imposed to encourage the user to improve power factor. Power companies usually impose a billing penalty when power factor (PF) drops below 90%, although this figure could be as high as 95%. In nearly all cases, the least expensive and most efficient method to reduce this charge is by adding capacitors.

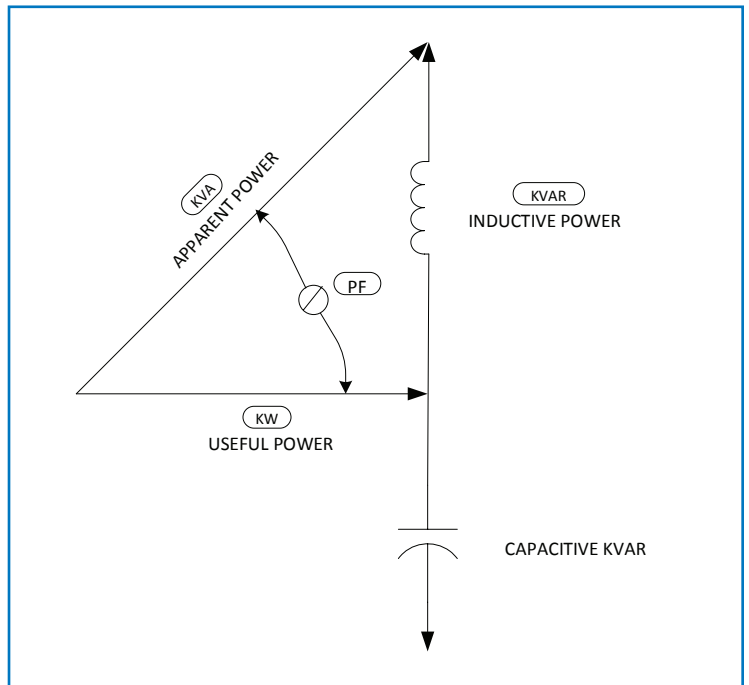

Location of Power Capacitors

Methods of Wiring to Induction Motor Circuits

Capacitors may be connected to each motor and switched with it, as in **Figures 1 and 2**, in which case they are energized only when the motor is in operation, or they may be permanently connected to the line ahead of motor starters as in **Figure 3**.

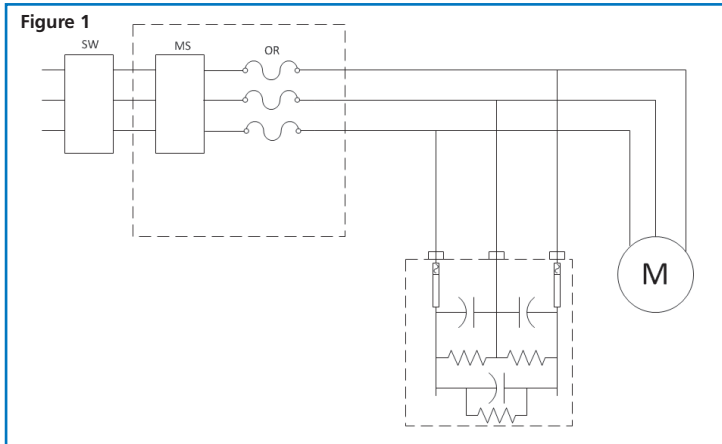

Figure 1

For new motor installations
Capacitors are connected on the motor side of the thermal-overload relay. The relay should be selected with a rating less than the motor nameplate full-load current, commensurate with reduced line current affected by the capacitors. This reduction in line current, if not available from tables, may be determined by measuring line current with and without capacitors, or by calculation.

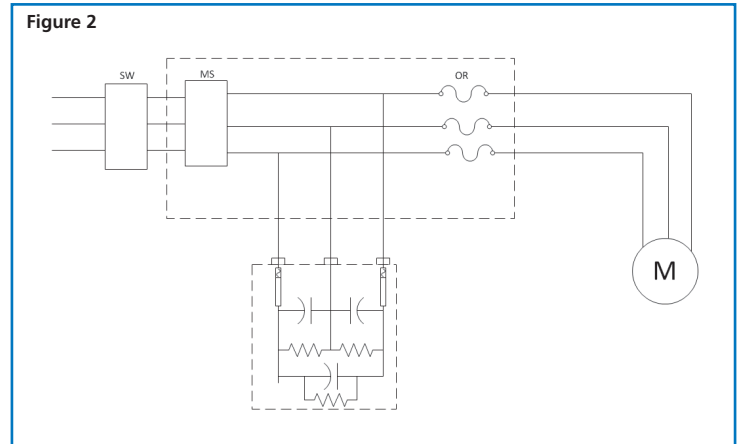
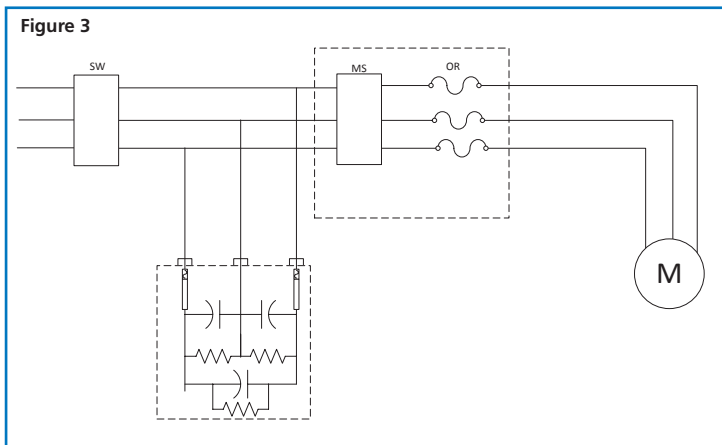

Figure 2

For existing motor installations
Capacitors are connected to the line side of the thermal-overload relay. In this case the overload relay does not have to be resized.



Capacitors are permanently connected to the line, but with protection of a fusible safety switch or circuit breaker, which eliminates a separate capacitor switch. To avoid nuisance blowing of the capacitor fuses, install the capacitors at this location when the motors are multiple-speed, reversing, jogging, inching, or reduced voltage start.

Legend:

SW = fusible safety switch or breaker
MS = motor starter
OR = motor thermal-overload relay
M = motor

Note: In **Figures 2 and 3**, the thermal-overload relay does not require replacement since full motor current continues to flow through it.

Power Capacitors Afford Kilovar Relief from Their Point of installation Toward the Power Source.

1. The most economical capacitor location is directly across the terminals of larger motors thereby eliminating the cost of a separate switch. The capacitor ratings may be selected directly from **Table 2** or **Table 3**, which require knowing only the type, horsepower rating, and speed of the motor. Reference to **Figure 1** or **2** indicates the recommended location for new and existing motors. These capacitor ratings normally correct the motor no-load power factor to unity which in turn generally results in a full-load power factor of 94%-96%.
2. Where there are multiple motors with low horsepower ratings, or motors which do not run continuously, the capacitors should be connected directly to feeders in the facility through an appropriate switching device to serve as a disconnect for servicing, or for light load conditions. The capacitors should be located as far downstream in the facility as possible for maximum benefit.
3. Installations may be made at load centers when it is difficult to connect the capacitors directly across motor terminals or to feeders. Again, switching is a recommended practice.
4. If only power bill penalties are to be offset, the total capacitor requirement can be installed on the load side of metering equipment. Such a location does not increase the capacity of the facility distribution system.

Table 2**Suggested Maximum Capacitor Ratings for U-Frame NEMA CIs B. Motors**

NEMA Motor Design A or B, Normal Starting Torque, Normal Running Current

H. P.	3600 RPM		1800 RPM		1200 RPM		900 RPM		720 RPM		600 RPM	
Rating	KVAR	%AR	KVAR	%AR	KVAR	%AR	KVAR	%AR	KVAR	%AR	KVAR	%AR
3	1.5	14	1.5	15	1.5	20	2	27	2.5	35	3.5	41
5	2	12	2	13	2	17	3	25	4	32	4.5	37
7.5	2.5	11	2.5	12	3	15	4	22	5.5	30	6	34
10	3	10	3	11	3.5	14	5	21	6.5	27	7.5	31
15	4	9	4	10	5	13	6.5	18	8	23	9.5	27
20	5	9	5	10	5	11	7.5	18	10	20	10	25
25	5	6	5	8	7.5	11	7.5	13	10	20	10	21
30	5	5	5	8	7.5	11	10	15	15	22	15	25
40	7.5	8	10	8	10	10	15	16	15	18	15	20
50	10	7	10	8	10	9	15	12	20	15	25	22
60	10	6	10	8	15	10	15	11	20	15	25	20
75	15	7	15	8	15	9	20	11	30	15	40	20
100	20	8	20	8	25	9	30	11	40	14	45	18
125	20	6	25	7	30	9	30	10	45	14	50	17
150	30	6	30	7	35	9	40	10	50	17	60	17
200	40	6	40	7	45	8	55	11	60	12	75	17
250	45	5	45	6	60	9	70	10	75	12	100	17
300	50	5	50	6	75	9	75	9	80	12	105	17

Table 3**Suggested Maximum Capacitor Ratings for T-Frame NEMA Class B. Motors**

Applies to three-phase, 60 HZ motors when switched with capacitors as a single unit.

Induction Motor Rating (HP)	Nominal Motor Speed											
	3600 R/MIN		1800 R/MIN		1200 R/MIN		900 R/MIN		720 R/MIN		600 R/MIN	
	Capacitor Rating (KVAR)	Line Current Reduction (%)	Capacitor Rating (KVAR)	Line Current Reduction (%)	Capacitor Rating (KVAR)	Line Current Reduction (%)	Capacitor Rating (KVAR)	Line Current Reduction (%)	Capacitor Rating (KVAR)	Line Current Reduction (%)	Capacitor Rating (KVAR)	Line Current Reduction (%)
3	1.5	14	1.5	23	2.5	28	3	38	3	40	4	40
5	2	14	2.5	22	3	26	4	31	4	40	5	40
7.5	2.5	14	3	20	4	21	5	28	5	38	6	45
10	4	14	4	18	5	21	6	27	7.5	36	8	38
15	5	12	5	18	6	20	7.5	24	8	32	10	34
20	6	12	6	17	7.5	19	9	23	10	29	12	30
25	7.5	12	7.5	17	8	19	10	23	12	25	18	30
30	8	11	8	16	10	19	14	22	15	24	22.5	30
40	12	12	13	15	16	19	18	21	22.5	24	25	30
50	15	12	18	15	20	19	22.5	21	24	24	30	30
60	18	12	21	14	22.5	17	26	20	30	22	35	28
75	20	12	23	14	25	15	28	17	33	14	40	19
100	22.5	11	30	14	30	12	35	16	40	15	45	17
125	25	10	36	12	35	12	42	14	45	15	50	17
150	30	10	42	12	40	12	52.5	14	52.5	14	60	17
200	35	10	50	11	50	10	65	13	68	13	90	17
250	40	11	60	10	62.5	10	82	13	87.5	13	100	17
300	45	11	68	10	75	12	100	14	100	13	120	17
350	50	12	75	8	90	12	120	13	120	13	135	15
400	75	10	80	8	100	12	130	13	140	13	150	15
450	80	8	90	8	120	10	140	12	160	14	160	15
500	100	8	120	9	150	12	160	12	180	13	180	15

Points to Consider when Sizing Capacitors

Two limiting factors must be considered when capacitors are to be switched with a motor as a unit. The first is overvoltage due to self-excitation, and the second is transient torques.

Self-excitation voltage: When a motor is disconnected from the line, it will normally rotate for a short time before coming to rest. A capacitor connected to this motor will still be supplying magnetizing current, which will excite the motor. Under these conditions, the motor and capacitor act like a generator and produce a certain voltage because of this "self-excitation." The magnitude of the voltage that can be produced is determined by two things — the rating of the capacitor being used and the speed of the motor involved. It is not uncommon for this "self-excitation" voltage to reach 150% of rated voltage if too large a capacitor is being used.

Transient torques: Perhaps even more important than overvoltage is the transient torques that can occur if the motor happens to close back into the line before coming to a complete rest. If the motor is still rotating and acting as a generator, the resulting transient torque may be as much as 20 times the full load torque.

Because of transient torque and overload considerations, most motor manufacturers provide recommendations concerning the maximum capacitor KVAR that should be switched with a given motor. These recommendations are conservative enough to avoid endangering the motor, and will ordinarily result in a corrected power factor of approximately 95-98% at full load.

To avoid nuisance blowing of fuses when capacitors are connected directly across the motor terminals:

1. Motors should not be subject to plugging or reversing duty.
2. Motors should not be operated such that rapid restarting occurs.

Switching Capacitors

The National Electrical Code requires that power capacitors, other than those directly connected across motor terminals, have separate disconnecting means to permit their removal from the circuit as a regular operating procedure, or for maintenance purposes. The Code also requires that the continuous current carrying capacity of the disconnecting device and of the capacitor circuit conductors shall be not less than 135% of the rated current of the capacitor.

Since power capacitors for industrial service are designed for use in an ambient temperature of 46°C (115°F) maximum, the cables and disconnecting devices should also be selected for this ambient operation.

The data in **Table 4** on page 14 is predicated on these conditions.

Percent AR is the percent reduction in full-load line current due to capacitors. A capacitor located on the motor side of the overload relay reduces current through the relay. Therefore, a smaller relay may be necessary. The motor-overload relay should be selected on the basis of the motor full-load nameplate current reduced by the percent reduction in line current (percent AR) due to capacitors.

The capacitor size specified in **Table 3** will increase the full load power factor to 95% and larger sizes should not be used without consulting Aerovox.

To calculate required KVAR for energy efficient motors (or any motor) use the following formula:

$$\text{KVAR} = \frac{\text{H.P.} \times .746}{\% \text{ efficiency}} \left(\sqrt{\frac{1 - \text{PF}_0^2}{\text{PF}_0^2}} - \sqrt{\frac{1 - \text{PF}_1^2}{\text{PF}_1^2}} \right)$$

PF₀ Original Power Factor (supplied by manufacturer)

PF₁ Target Power Factor

H.P. Motor Horsepower from nameplate

% efficiency Motor manufacturer nameplate

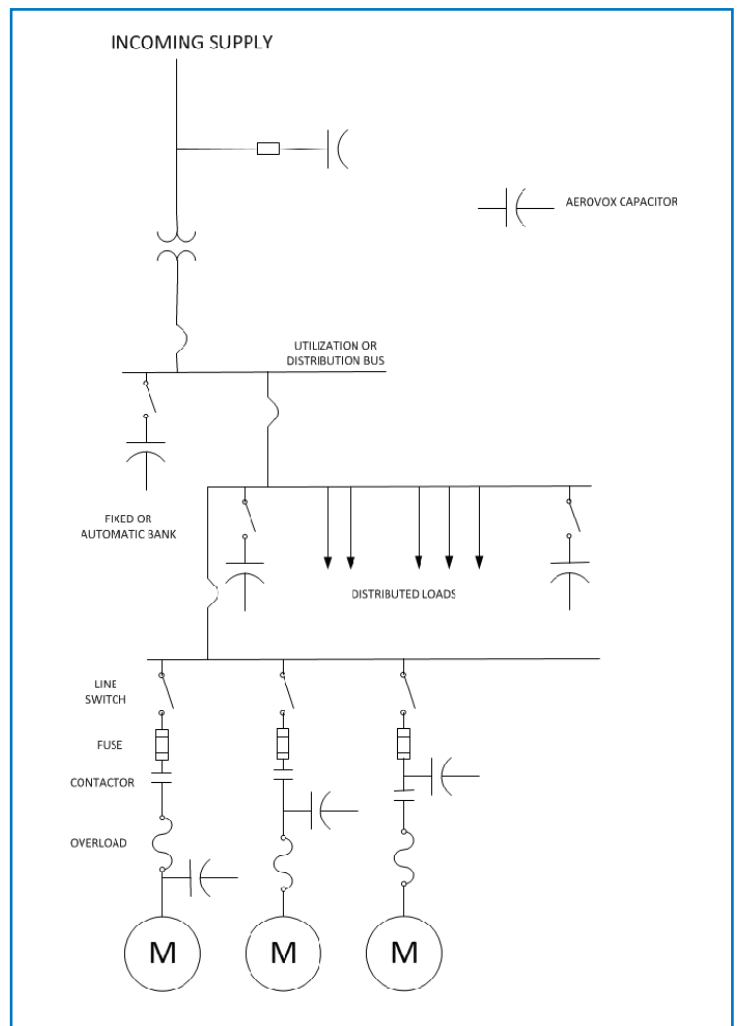

Table 4**Suggested Wire Sizes for Capacitor Installations**

The cable sizes indicated in **Table 4** are based on 135% of rated current in accordance with NEC 460.

240 Volt, 3 Phase					480 Volt, 3 Phase					600 Volt, 3 Phase				
Cap. Rating KVAR	75°C Min. Cable Sizes *	90°C Min. Cable Sizes *	Safety Switch		Cap. Rating KVAR	75°C Min. Cable Sizes *	90°C Min. Cable Sizes *	Safety Switch		Cap. Rating KVAR	75°C Min. Cable Sizes *	90°C Min. Cable Sizes *	Safety Switch	
			Rating AMPS	Fuse AMPS				Rating AMPS	Fuses AMPS				Rating AMPS	Fuse AMPS
0.5	14	14	30	3	0.5	14	14	30	1	0.5	14	14	30	1
1	14	14	30	5	1	14	14	30	3	1	14	14	30	3
2	14	14	30	10	1.5	14	14	30	3	1.5	14	14	30	3
2.5	14	14	30	10	2	14	14	30	6	2	14	14	30	3
3	14	14	30	15	2.5	14	14	30	6	2.5	14	14	30	5
4	12	12	30	20	3	14	14	30	6	3	14	14	30	5
5	12	12	30	20	4	14	14	30	10	4	14	14	30	6
6	10	10	30	25	5	14	14	30	10	5	14	14	30	10
7.5	10	10	30	30	6	14	14	30	15	6	14	14	30	10
8	8	8	60	35	7.5	14	14	30	15	7.5	14	14	30	15
10	8	8	60	40	8	12	12	30	20	8	14	14	30	15
12.5	8	8	60	50	10	12	12	30	20	10	12	12	30	20
15	6	6	60	60	12.5	10	10	30	25	12.5	12	12	30	20
17.5	4	6	100	75	15	10	10	30	30	15	10	10	30	25
20	4	4	100	80	17.5	8	8	60	35	17.5	10	10	30	30
22.5	3	4	100	90	20	8	8	60	40	20	8	8	60	35
25	3	3	100	100	22.5	8	8	60	50	22.5	8	8	60	40
27.5	1	2	200	125	25	8	8	60	50	25	8	8	60	40
30	1	2	200	125	27.5	6	6	60	60	27.5	8	8	60	45
35	1/0	1	200	150	30	6	6	60	60	30	8	8	60	50
40	2/0	2/0	200	175	35	4	6	100	70	35	6	6	60	60
45	3/0	3/0	200	200	40	4	4	100	80	40	4	6	100	70
50	3/0	3/0	200	200	45	3	4	100	90	45	4	4	100	80
60	250	4/0	400	250	50	3	3	100	100	50	4	4	100	80
75	350	300	400	300	60	3	3	200	110	60	3	3	100	100
100	2x3/0	3x3/0	400	400	75	1/0	1	200	150	75	1	2	200	125
125	2x250	2x4/0	600	500	100	3/0	2/0	200	200	100	1/0	1	200	150
150	2x350	2x300	600	600	125	250	4/0	400	250	125	3/0	3/0	200	200
175	2x500	2x350	800	700	150	350	300	400	300	150	250	4/0	400	250
200	2x600	2x500	800	800	175	500	350	400	350	175	350	300	400	300
225	3x350	3x300	1,200	900	200	2x3/0	2x3/0	400	400	200	500	350	400	350
250	3x350	3x350	1,200	1,000	225	2x3/0	2x3/0	400	400	225	2x3/0	2x3/0	400	400
275	4x300	3x400	1,200	1,100	250	2x250	2x4/0	600	500	250	2x3/0	2x3/0	400	400
300	4x350	3x500	1,200	1,250	275	2x250	2x4/0	600	500	275	2x4/0	2x3/0	600	450
					300	2x350	2x300	600	600	300	2x250	2x4/0	600	500
					325	2x500	2x350	800	700	325	2x250	2x4/1	600	500
					350	2x500	2x350	800	700	350	2x350	2x300	600	600
					375	2x600	2x500	800	800	375	2x350	2x300	600	600
					400	2x600	2x500	800	800	400	2x500	2x350	800	700
					425	3x350	2x300	1,200	900	425	2x500	2x350	800	700
					450	3x350	2x300	1,200	900	450	2x500	2x400	800	750
					475	3x350	2x300	1,200	900	475	2x500	2x400	800	750
					500	3x400	3x350	1,200	1,000	500	2x600	2x500	1,200	800
					525	3x400	3x350	1,200	1,000	525	2x600	2x500	1,200	800
					550	4x300	3x400	1,200	1,100	550	3x350	2x600	1,200	900
					575	4x350	3x500	1,200	1,200	575	3x350	2x600	1,200	900
					600	4x350	3x500	1,200	1,200	600	3x400	3x350	1,200	1,000

*Not more than three single conductors are allowed in a raceway with 30°C ambient. For higher ambient temperatures, consult the National Electrical Code Table 310-16 (correction factor for ambients over 30°C). Rated current is based on operation at rated voltage, frequency, and KVAR.

Understanding Harmonics

Harmonics are multiples of the fundamental frequency distortions found in electrical power, subjected to continuous disturbances. In a 60 Hz electrical system, 300 Hz is the 5th harmonic, 420 Hz is the 7th harmonic, and so on. These harmonics are created by the increased use of non-linear devices such as UPS systems, solid state variable speed motor drives, rectifiers, welders, arc furnaces, fluorescent ballasts and personal computers. The source of these harmonics may be internal or external. Individual harmonic frequencies will vary in amplitude and phase angle, depending on the harmonic source. Variable speed drives are usually referred to by the number of rectifiers in the system. The most common are six (rectifiers) and twelve (rectifiers) pulse drives.

Harmonic Resonance occurs when the capacitor reactance and the system reactance are equal. If this occurs, large harmonic currents will circulate between transformer and capacitor. These currents will result in greater voltage distortion. This provides a higher voltage across the capacitor and potentially harmful currents through all capacitor equipment. Harmonic resonance may occur at any frequency but the 5th, 7th, 11th and 13th are the frequencies with which we are most concerned. If total bus load exceeds 15-20% of harmonic generation load, the potential for a resonance condition is high. Some indicators of resonance are overheating, frequent circuit breaker tripping, unexplained fuse operation, capacitor failure, electronic equipment malfunction, flicking lights and telephone interference.

Conquering Harmonic Resonance can be accomplished by:

1. Adding or subtracting capacitance from the system to move the parallel resonance frequency to one that is not deleterious;
2. Adding tuned harmonic suppression reactors in series with the capacitor to prevent resonance;
3. Altering the size of non-linear devices. It is important that the tuned frequency, for the 5th harmonic, be at approximately the 4.7th harmonic to account for tolerance in manufacturing and to remove the largest offending portion of the 5th harmonic. Parallel resonance will occur around the 4th harmonic, at a much lower amplitude and in an area that does no harm to the system or capacitor. Tuning lower than 282 Hz is not efficient in removing large portions of the offending harmonic.

Considerations of how power factor correction capacitors affect a system are of utmost importance. In systems with more than 15-20% of harmonic loads, a harmonic survey should be performed to indicate potential problem areas. Readings taken over changing load conditions at potential capacitor locations are most useful in determining the types of systems best employed to accomplish the ultimate harmonic suppression, power factor improvement, KVA reduction and other goals.

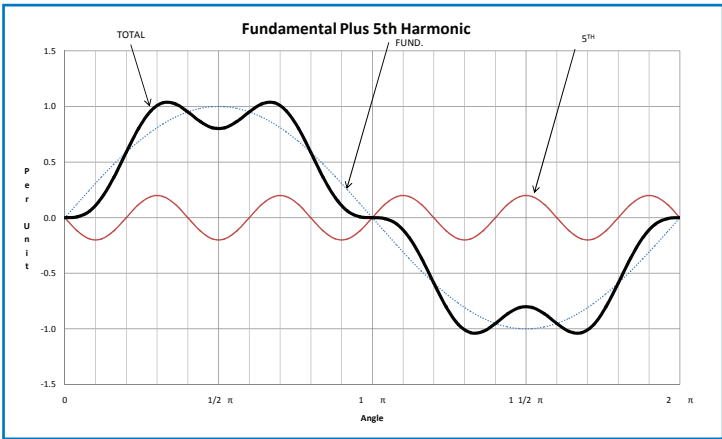

Applying Power Factor Correction in a Harmonic Environment

The use of capacitors has long been accepted as the most practical solution to low power factor problems in power systems.

Modern capacitors are a reliable, maintenance free, inexpensive source of VAR's needed in inductive circuits to synchronize the voltage and current waveforms.

In the past, the application of capacitors was straightforward; all that was required was a knowledge of KW (or KVA), existing power factor, and target power factor. In recent years, however, this practice has been complicated by the proliferation of non-linear loads.

The Source of the Problem

One of the most widely used solid state motor controls is the six-pulse drive. These devices represent a non-linear impedance to the power source, drawing a quasi-square wave alternating current rich in harmonics.

For six-pulse drives, the characteristic harmonics are: 5, 7, 11, 13, 17, 19, ...; the higher order harmonics are not usually troublesome because their magnitude is progressively smaller. **Figure 4** shows the total distortion when one or more harmonics are added to the fundamental.

Harmonic Resonance

When a capacitor bank is added to a power system, it is effectively connected in parallel with the system's impedance, which is primarily inductive. As far as the harmonic source is concerned, it sees a capacitor in parallel with an inductor.

Figure 5 shows the model circuit for this system on a per phase basis. Resistor 'R' represents the inevitable system losses. The harmonic source is represented as a constant current source, since it behaves as such.

Since the capacitive (X_c) and inductive (X_L) reactances are frequency dependent (as frequency increases, X_c decreases and X_L increases), there is a frequency at which these two parameters will be equal; this frequency is called the system's *natural resonant frequency*.

At this frequency, the system's impedance appears to the harmonic source to be very large, therefore, a harmonic current at the resonant frequency flowing through this impedance will result in a very large harmonic voltage as derived by Ohm's Law ($V_n = I_n Z_n$).

A large harmonic voltage will in turn result in a much larger harmonic current exchange between the capacitor bank and the system impedance. This secondary harmonic current may be many orders of magnitude larger than the *generated* harmonic current, resulting in nuisance operation of circuit breakers or fuses that happen to be in the path of this current.

The degree of magnification is determined by the system resistance.

Since the generated harmonic current is considered to be constant for a given frequency, then the harmonic voltage will be proportional to the impedance. Consequently, the frequency response of the impedance is a good indication of the system's susceptibility to harmonic resonance.

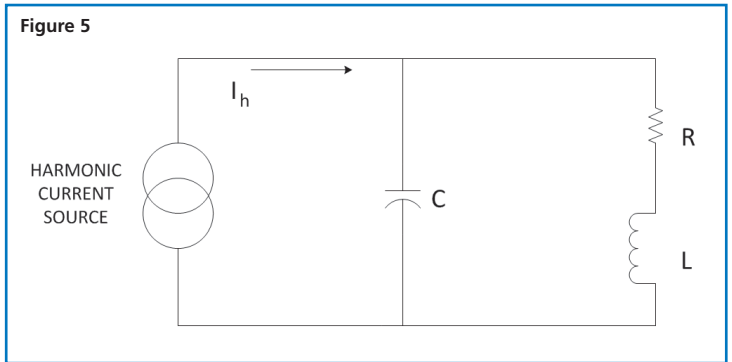
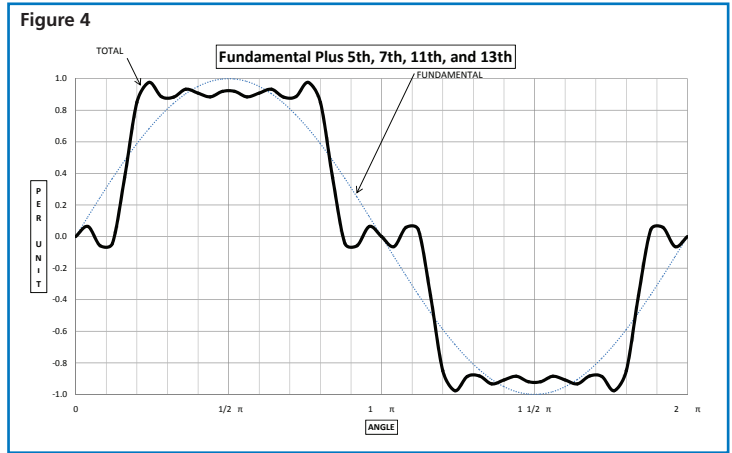

Figure 6 is the impedance plot, as seen by the harmonic source in **Figure 5**, for a typical system consisting of 500 KVAR connected to a 1500 KVA, 480 volt transformer. (While impedance magnitudes are dependent on system resistance, resonant frequency is primarily a function of inductance (L) and capacitance (C).)

The quick and simple way to calculate the system's harmonic resonance is through the following relationship derived from the system's reactances:

$$h = \sqrt{\frac{KVA_{SC}}{KVAR}}$$

where: h = harmonic order

$$KVA_{SC} = \frac{KVA}{Z_{pu}} = \text{available short circuit at point of capacitor bank installation}$$

KVAR = capacitor bank size

This calculation, even though it does not take into account upstream system impedance, is reasonably accurate for most applications since the bulk of the impedance is contributed by the transformer itself.

Detuning the Circuit

The most effective solution to this problem consists of series tuning the capacitor bank to the lowest offending harmonic, usually the 5th. This is done by introducing an inductor in series with the capacitor as shown in **Figure 7**.

The impedance versus frequency plot, as seen by the harmonic source, is shown in **Figure 8**; the original impedance response (untuned) is shown for comparison.

The minimum impedance occurs at the series resonant point, the 4.7th harmonic, while the peak represents a parallel resonance due to the capacitor and the two inductors. Harmonic currents generated at or near the series resonant frequency (such as the 5th) will flow to the trap harmlessly, provided the capacitor and reactor are sized properly to withstand the additional stresses. These currents are simply following the path of least impedance. The system will not resonate above this frequency since it is inductive.

This approach will accomplish two objectives. On the line side of the capacitor filter bank, system power factor is corrected and harmonic voltage distortion is reduced. Harmonic voltage (V_h) is the result of a harmonic current (I_h) flowing through the system impedance (Z_h), i.e. Ohm's Law ($V_h = I_h Z_h$). By reducing the system impedance (Z_h) we can reduce the harmonic voltage (V_h) even though the harmonic current (I_h) remains the same.

When the main objective is to reduce harmonic distortion, the engineer will consider the use of more filter stages, each tuned to the next higher harmonic (7th, 11th,...). In some cases, where harmonic currents are excessive, the use of capacitors rated at the next higher voltage may be required. In most cases, Aerovox capacitors are run at rated voltage and will maintain their twenty year life expectancy.

Conclusion

There are many factors to consider when applying system power factor correction. Properly sized and applied power factor correction capacitors in industrial applications will increase system power factor with the benefit of a reduction in utility costs associated with poor power factor, reduce the effects of potentially damaging harmonics, reduce system losses and release capacity. In conclusion, use of power factor correction capacitors is an economical solution to providing improved power quality to AC electric power systems.

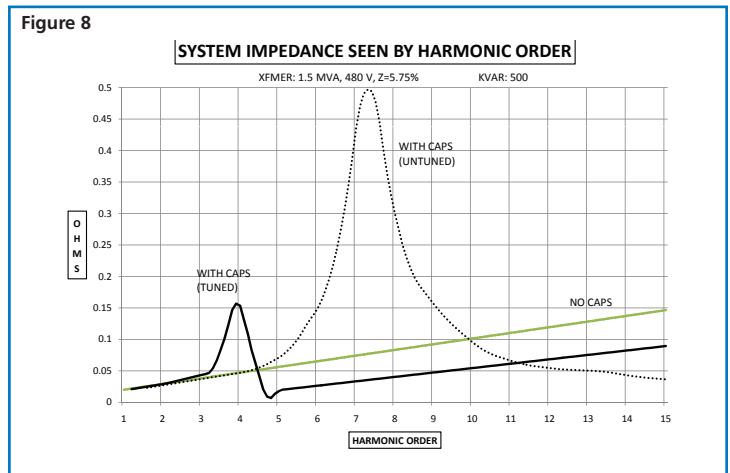
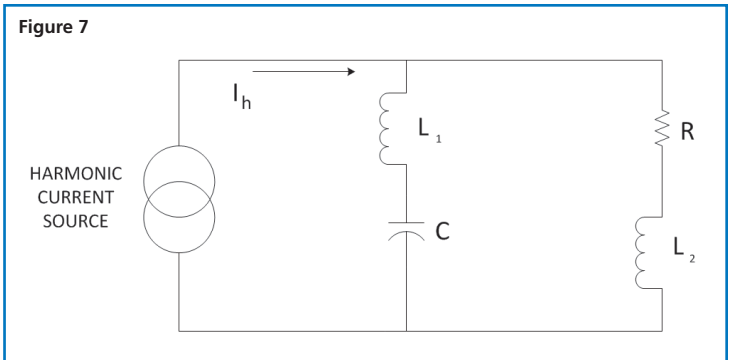
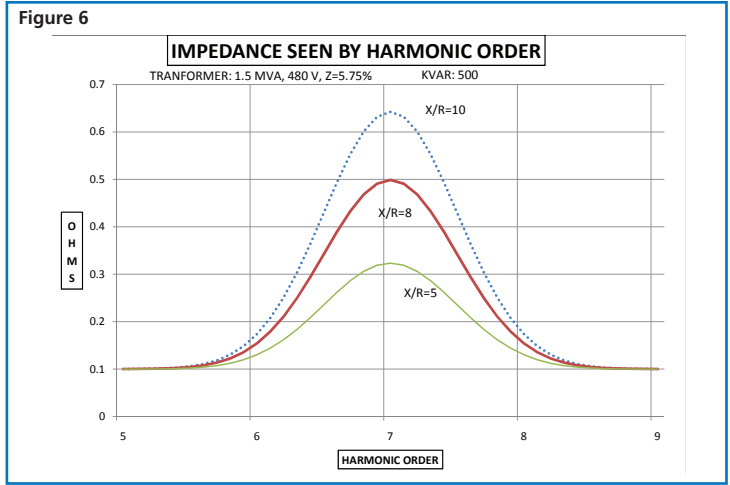

About Aerovox

Aerovox is a leading provider of film capacitors for industrial, medical and specialized applications serving original equipment manufacturers (OEM) and distributors. The company has world-class design, manufacturing and testing facilities in New Bedford, Massachusetts and global manufacturing facilities in China and India to enable quick turn-around for shipping and delivery worldwide.

Aerovox capacitors are among the world's most reliable components. Our extensive custom design and development capabilities coupled with broad, standardized product offerings allow us to provide intelligent capacitor solutions that meet or exceed our customers' application requirements.

Our aim is to be the best and most sought after provider of capacitor solutions for specialty markets.

Aerovox[®]

Aerovox Corp.
167 John Vertente Blvd.
New Bedford, MA 02745
Tel: +1-508-994-9661
Fax: +1-508-995-3000
www.aerovox.com

Aerovox China
28 Wangchun Rd.
Ningbo, Zhejiang
China

Aerovox India
Plot # 30 to 33
Hardware Park
Imarat Kancha
Raviryal Village
Maheshwaram Mandal
R R District – 500 066
Andhra Pradesh State
India

Copyright 2013, Aerovox Corp. All rights reserved.
Aerovox is a registered trademark of Aerovox Corp.

AN101312 Printed in the USA